

THIS DRAWING IS UNPUBLISHED. RELEASED FOR PUBLICATION  
 © COPYRIGHT - By - ALL RIGHTS RESERVED.

LOC		DIST		REVISIONS			
P	LTR	DESCRIPTION		DATE	DWN	APVD	
CM	00	H2		REVISED PER ECO-11-004820	11MAR11	RK HMR	

- 1 WIRE RANGE: 0.2-0.82mm<sup>2</sup> (24-18 AWG)
- 2 INSULATION RANGE: 1.50 - 3.10 DIA.
- 3 FINISH: 0.76μm MINIMUM GOLD IN LOCALIZED GOLD PLATE AREA OVER 1.27μm MINIMUM NICKEL.
- 4 FINISH: 2.54μm MINIMUM PRE-TIN IN LOCALIZED TIN PLATE AREA.
- 5 FINISH: 2.54μm MINIMUM PRE-TIN ALL OVER.

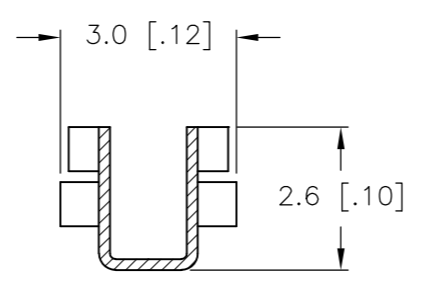
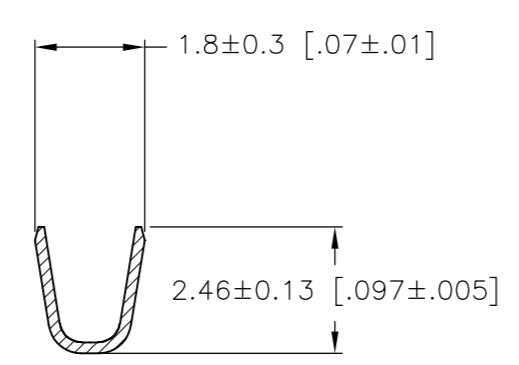
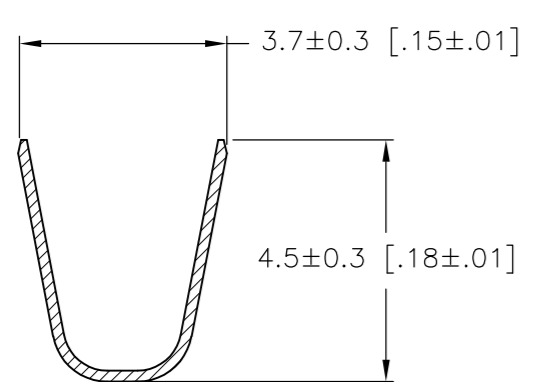
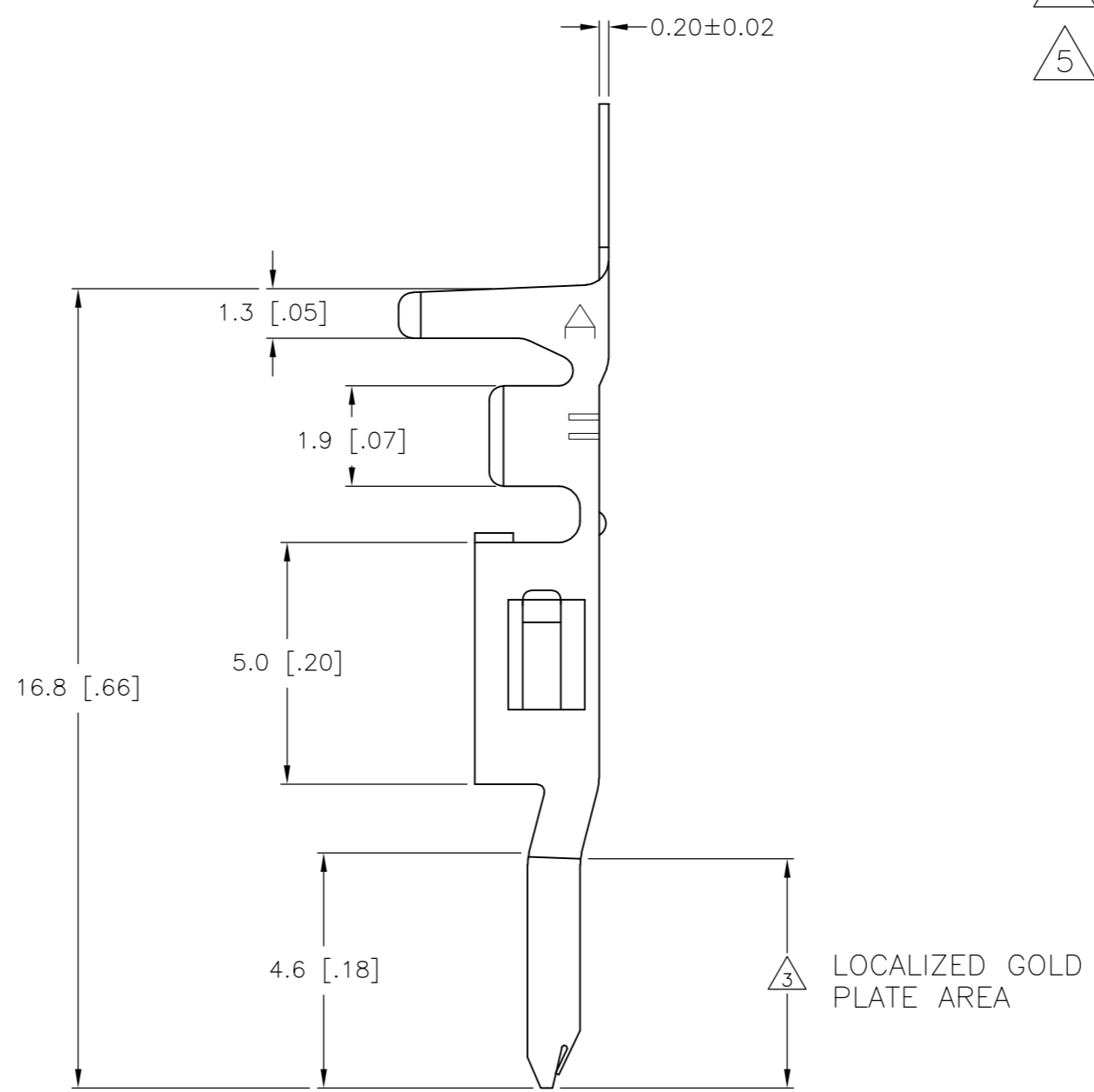
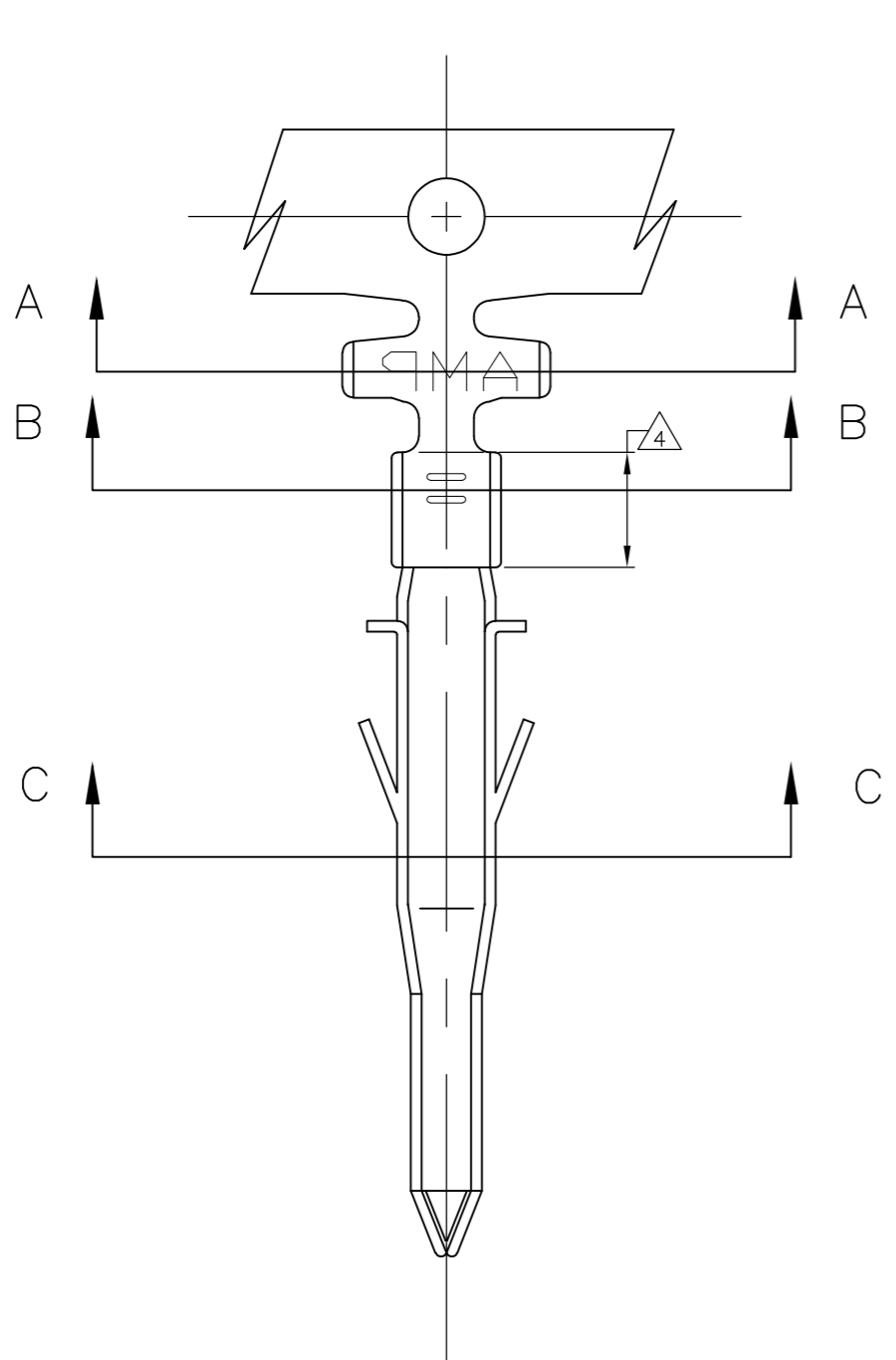

SECTION A-A

SECTION B-B

SECTION C-C

GOLD 3 4	PHOS. BRZ.	794955-4
PRE-TIN 5	PHOS. BRZ.	794955-3
GOLD 3 4	BRASS	794955-2
PRE-TIN 5	BRASS	794955-1
FINISH	MATERIAL	PART NO.

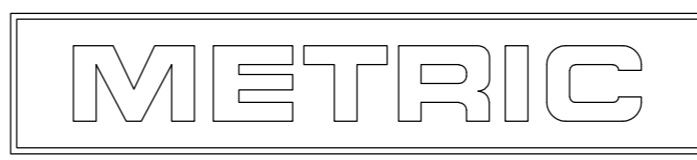

THIS DRAWING IS A CONTROLLED DOCUMENT.		DWN S. HAMM 07-SEP-2001		
DIMENSIONS: mm [INCHES]		CHK D. COLEY 07-SEP-2001		
TOLERANCES UNLESS OTHERWISE SPECIFIED:		APVD D. COLEY 07-SEP-2001	NAME	
0 PLC ±	1 PLC ± 0.25 [.010]	PRODUCT SPEC	TERMINAL PIN VAL-U-LOK(TM)	
2 PLC ± 0.15 [.006]	3 PLC ± 0.050 [.0020]	APPLICATION SPEC	SIZE A2	CAGE CODE 00779
4 PLC ±	ANGLES ±	WEIGHT	DRAWING NO C=794955	RESTRICTED TO -
MATERIAL	FINISH	CUSTOMER DRAWING	SCALE 10:1	SHEET 1 of 1
			REV H2	