

1. FOR USE WITH RG-214/U
2. BRAID CRIMP: USE MILITARY TOOL M22520/5-01, WITH DIE SET M22520/5-25, CAVITY A OR EQUIVALENT
3. CENTER CONTACT CRIMP: USE MILITARY TOOL M22520/5-01, WITH DIE SET M22520/5-25, CAVITY B OR EQUIVALENT

RECOMMENDED STRIP LENGTH
 SCALE 1:1

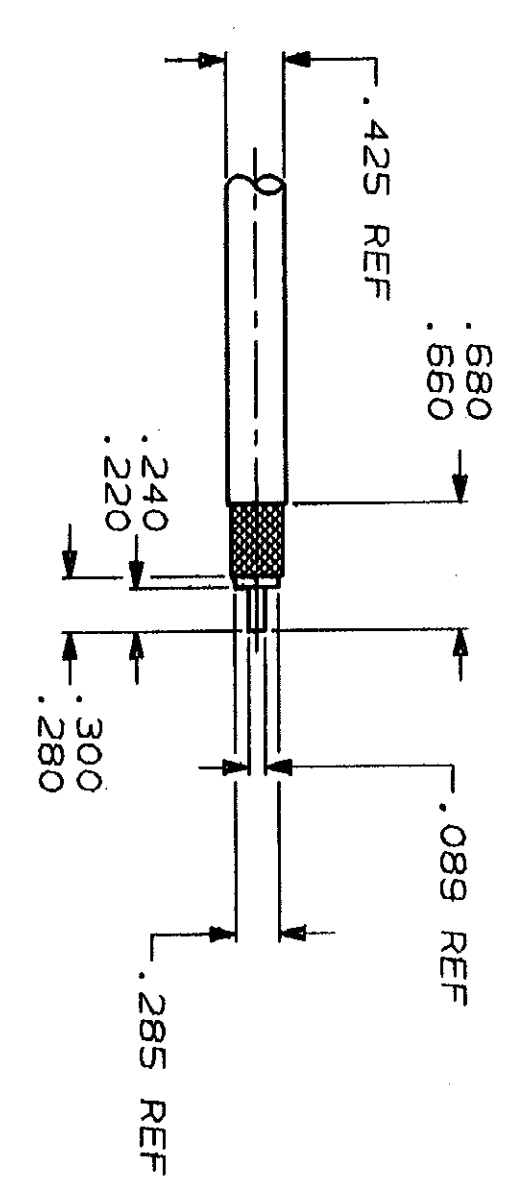

LOC	DIST	REV	DATE	APPD
DF	X0	0	RELEASED NPR 90-0064	PY

QTY	PART NO	DESCRIPTION	ITEM NO
1	447091-3	CONTACT, FEMALE	4
1	228143-4	HEAT SHRINK TUBING	3
1	447101-1	SOCKET ASSEMBLY	2
1	446556-9	FERRULE	1

DR	P. YEAGER	2-13-90	NAME	AMP INCORPORATED Merrilldale, Pa. 17105
CHK	J. CABARLO	2-26-90		
APPD	R. HOSLER	2-28-90		
APPD				
PRODUCT SPEC				
FINISH				

COAXIAL CONTACT,
 SOCKET, SIZE 1

DO NOT SCALE PRINT. UNLESS SPECIFIED DIMENSIONS IN INCHES TOLERANCES IN INCHES	DR	P. YEAGER	2-13-90	NAME	AMP INCORPORATED Merrilldale, Pa. 17105
1 PLC DEC # .005	CHK	J. CABARLO	2-26-90		
2 PLC DEC # .005	APPD	R. HOSLER	2-28-90		
3 PLC DEC # .005	APPD				
ANGLES #	PRODUCT SPEC				
MATERIAL	APPLICATION SPEC				
FINISH	WEIGHT				

SIZE	FSCM NO	DRAWING NO
C	00779	447087-1
SCALE	4:1	SHEET 1 OF 1

CUSTOMER DRAWING